

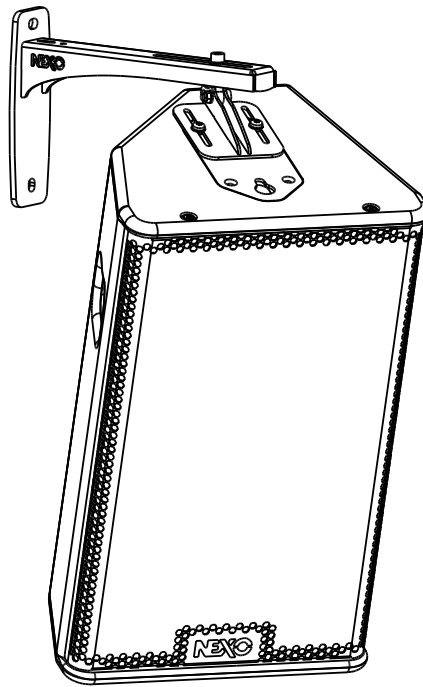

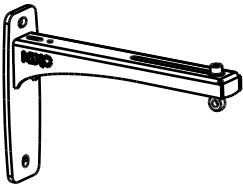





PS10 Wall Bracket

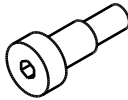
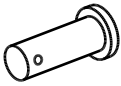

Contents:

<p>X1 (Arm)</p> 	<p>X1 (Adapter)</p> 	<p>X1</p> 	
<p>X3</p> 	<p>X2</p> 	<p>X1</p> 	
<p>X1</p> 	<p>X1</p> 	<p>X1</p> 	<p>X1</p> 

Weight: 1.35 kg / 3 lb

Dimensions:

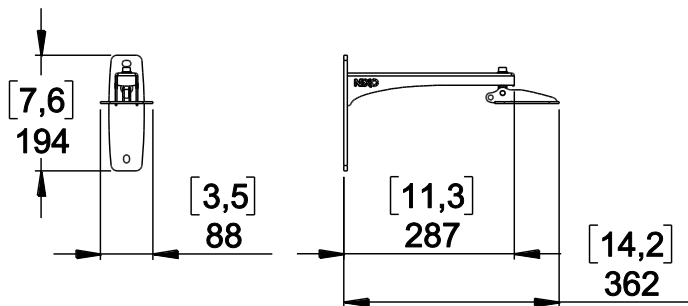

Adapter mounting

- Remove 2 screws from the PS10 and use the 2 screws and the 2 washers provided to fix the adapter.
- Please, do not push on the 2 screws while screwing them, to avoid disengaging the bolt that is inside the cabinet.
- **WARNING:** Screws must be secured using Loctite 243™

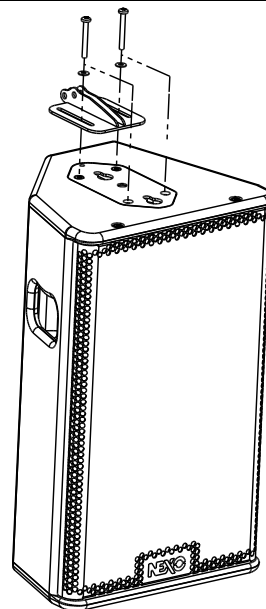

Mounting position

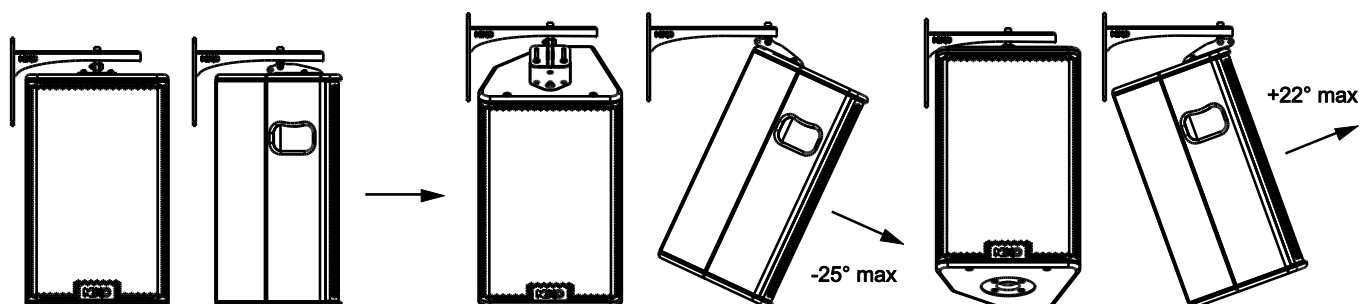
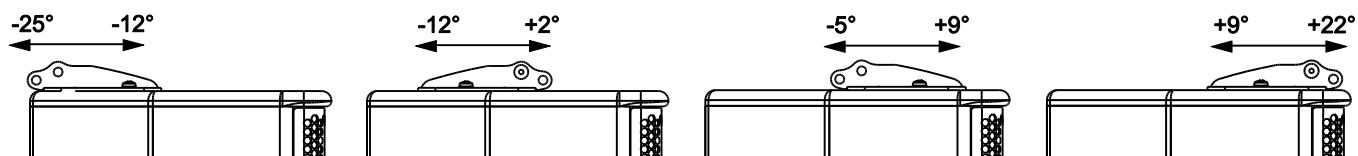

NEXO

nexo-sa.com
 ZA du Pre de la Dame Jeanne
 60128 PLAILLY - France

- Read this document before using.
- Keep this document.
- Observe all warnings and cautions.



Adapter / Arm mounting

For the wall mount of VNI-WS10, please select screws and mounting location supporting 4 times the system weight.

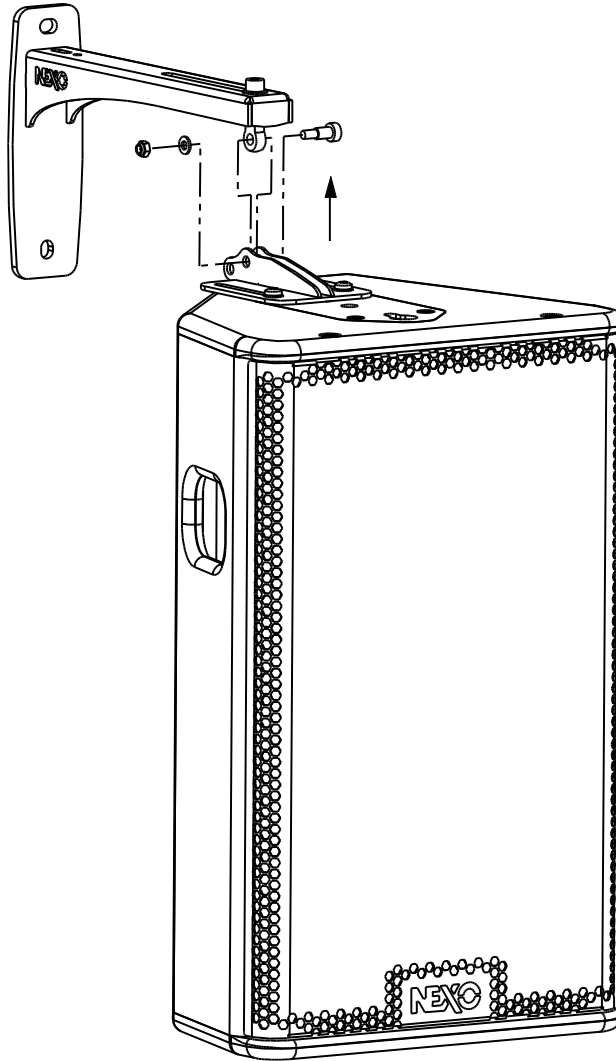

Tighten well to cancel any float between the arm and the adapter.

NEXO

nexo-sa.com

ZA du Pre de la Dame Jeanne
60128 PLAILLY - France

- Read this document before using.
- Keep this document.
- Observe all warnings and cautions.



Safety device

Use the parts provided

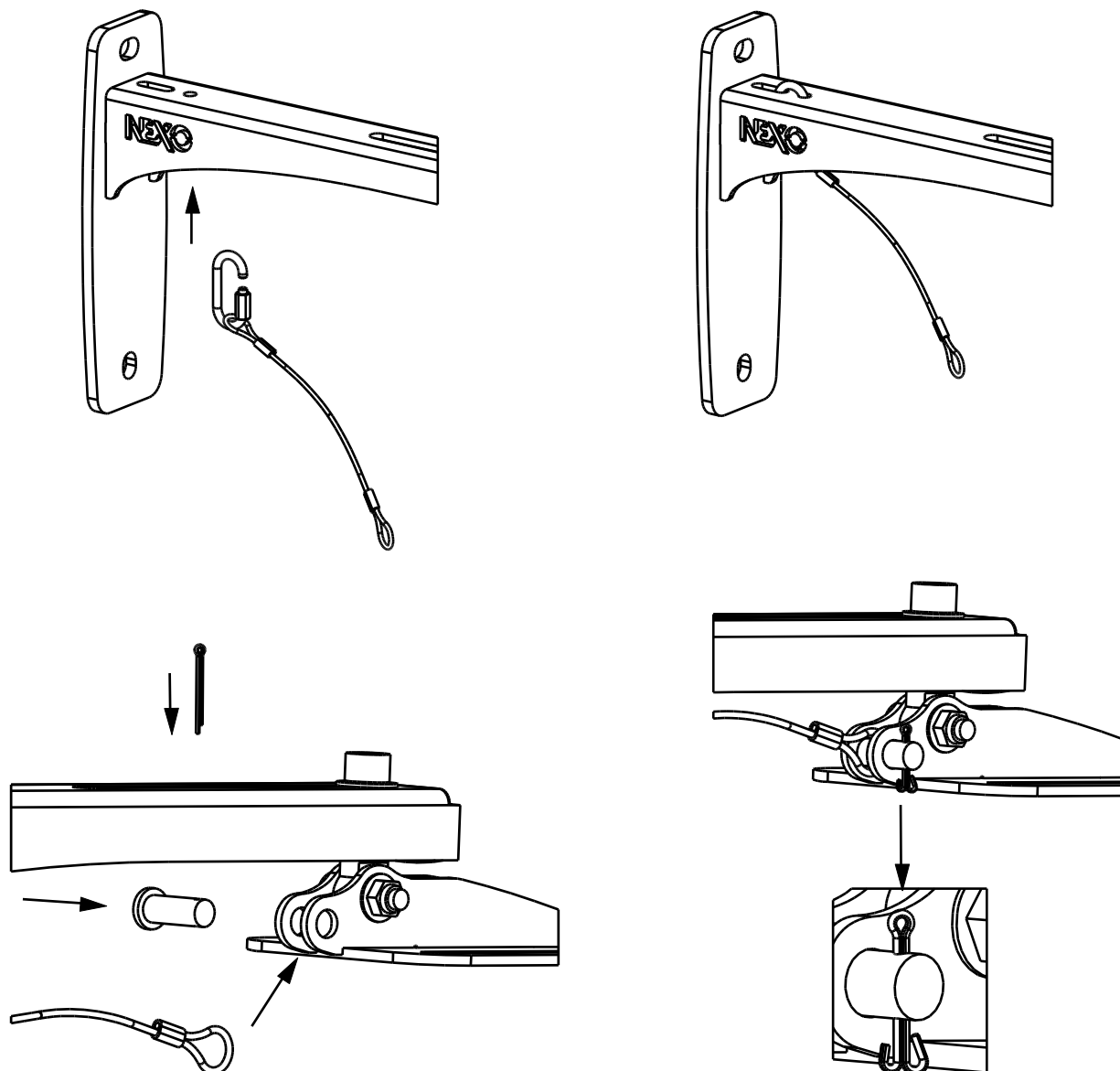

- NEXO cannot accept responsibility for accidents caused by any factor other than defects in this product itself.
- Please check the web site nexo-sa.com for the latest update.

NEXO

nexo-sa.com
ZA du Pre de la Dame Jeanne
60128 PLAILLY - France

- Read this document before using.
- Keep this document.
- Observe all warnings and cautions.

