

Fixing hanging bracket 450mm

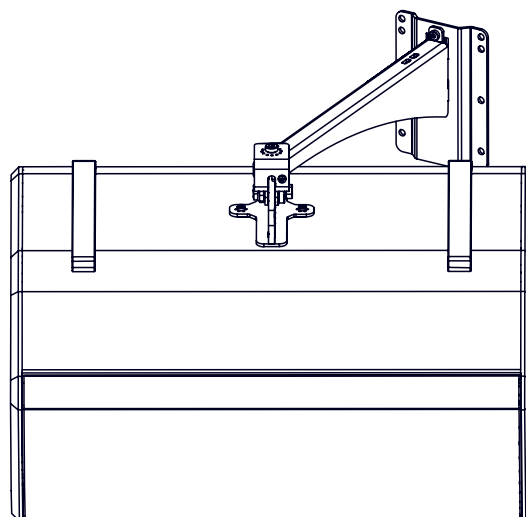
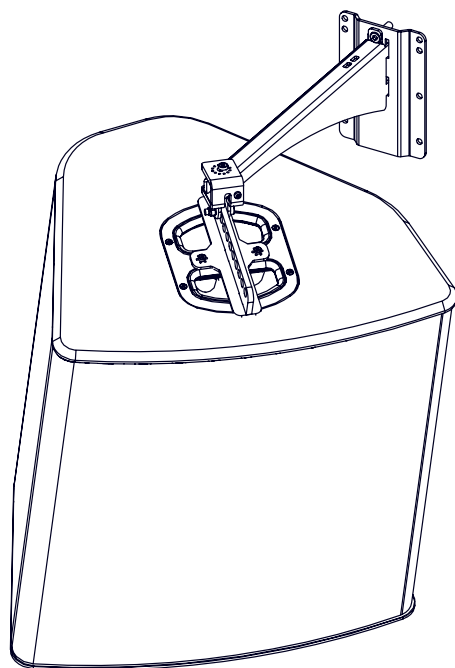
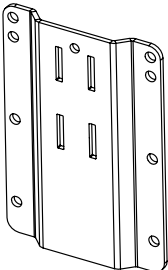
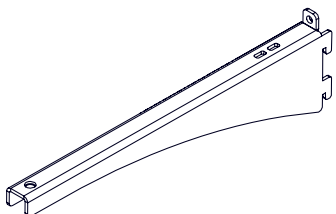
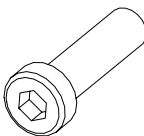
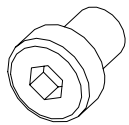

Contents:

<p>X1</p> 	<p>X1</p> 	<p>X1 VXTCHC1035 M10x35</p> 	<p>X1 VXTCHC810 M8x10</p> 
-----------------------------------------------------------------------------------------------	-----------------------------------------------------------------------------------------------	--------------------------------------------------------------------------------------------------------------------------	-------------------------------------------------------------------------------------------------------------------------

Weight: 2.7 kg / 6 lb

Dimensions:

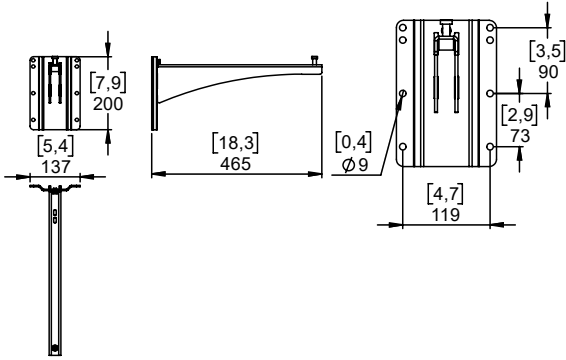

Safety Notes:

Please, select screws and mounting location supporting 4 times the system weight.
Inspect bolted assemblies periodically.

Use:

Mount the wall plate. Place the arm in the wall plate.

Lock with the provided screw.

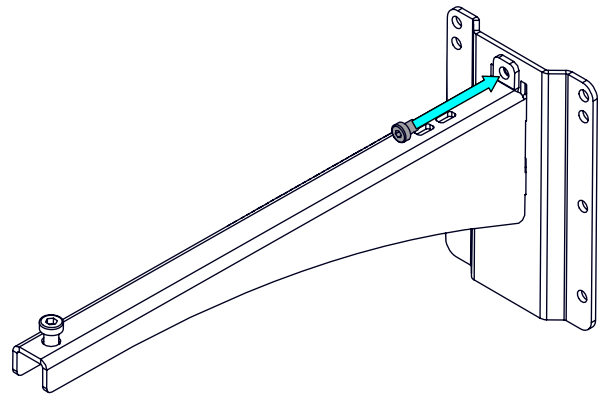
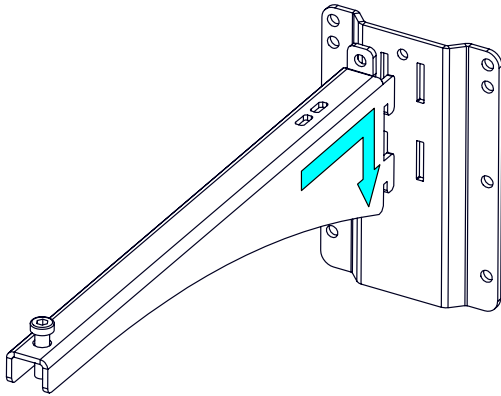

With P+ serie / HBRK or VBRK

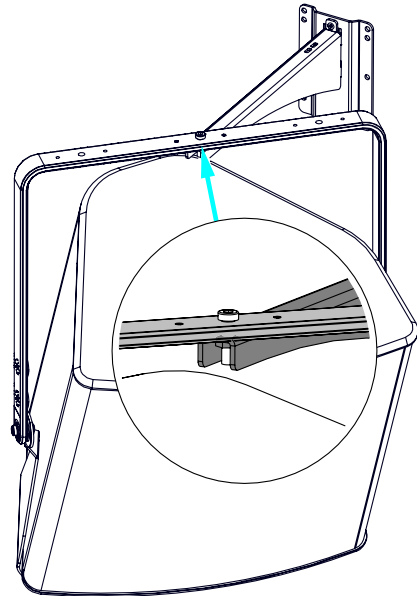
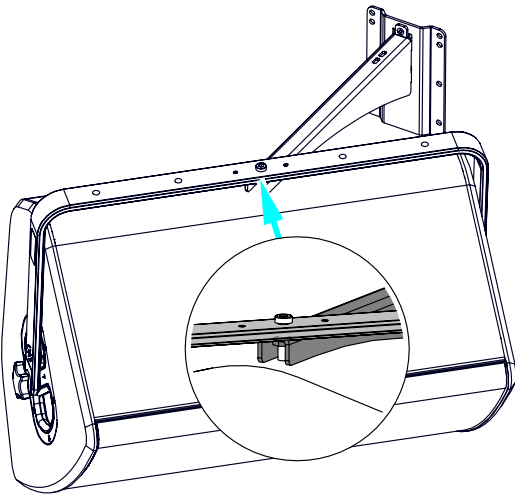

- NEXO cannot accept responsibility for accidents caused by any factor other than defects in this product itself.
- Please check the web site nexo-sa.com for the latest update.

NEXO

nexo-sa.com
ZA du Pre de la Dame Jeanne
60128 PLAILLY - France

- Read this document before using.
- Keep this document.
- Observe all warnings and cautions.

