



α+ series

Hybrid Source Sound Reinforcement



Touring



Live
Events



Clubs



Theatres

nexo-sa.com

Thinking. Inside the box.

NEXO

A
Yamaha
Group
Company

α+ series

Shaping the Future

By Celebrating our Past

Three decades on and original NEXO Alpha systems are still thrilling live music audiences and clubbers around the world with their characteristic power and presence. Now we've drawn on the spirit of that '90s classic to create Alpha+, an ultra-powerful, long-throw, 'three-box' FOH system that combines the benefits of line source coupling with the easy deployment typical of point source speakers.

Stacked on a mid-sized festival stage, installed in a club or deployed in a theatre where a line array can't be flown, it's all Alpha, reimagined for the modern age.

Thanks to the NEXO Touring WhatsApp family for contributing pictures of their original Alpha systems.



α + series

Show Up. Stack Up. Blow Away.

Two thousand people in a festival field with a varied program of rock bands and dance acts. Why wait and pay for towers to be built when Alpha+ is out of the truck and ground stacked in no time, with the power, punch and presence necessary to put a big smile on everyone's faces – audience, artists and technical crew.

148dB

And Alpha+ is so much better than a few line array boxes pole mounted on a sub. The HF dispersion control of the M210 Main module comes not from rigging angles between boxes, but from an ingenious waveguide block that can be 'unlocked' and its articulation changed from Narrow vertical coverage ($-20^{\circ}/+0^{\circ}$) to Wide/Standard ($-20^{\circ}/+20^{\circ}$), while the continuously varying horizontal directivity from 60° at the top to 120° at the bottom can be modified to $90^{\circ}/120^{\circ}$ or $60^{\circ}/60^{\circ}$ using magnetic flanges.

A horn-loaded 2 x 10" coaxially mounted with 4 x 3" HF compression drivers, the M210 achieves an impressive 148dB peak SPL and makes its presence felt very clearly from 30 metres. What's more, it sits at the perfect height to achieve excellent audience coverage on top of B218 Bass and L20 Sub modules that extend LF performance down to 28Hz with cardioid configuration limiting spillage.



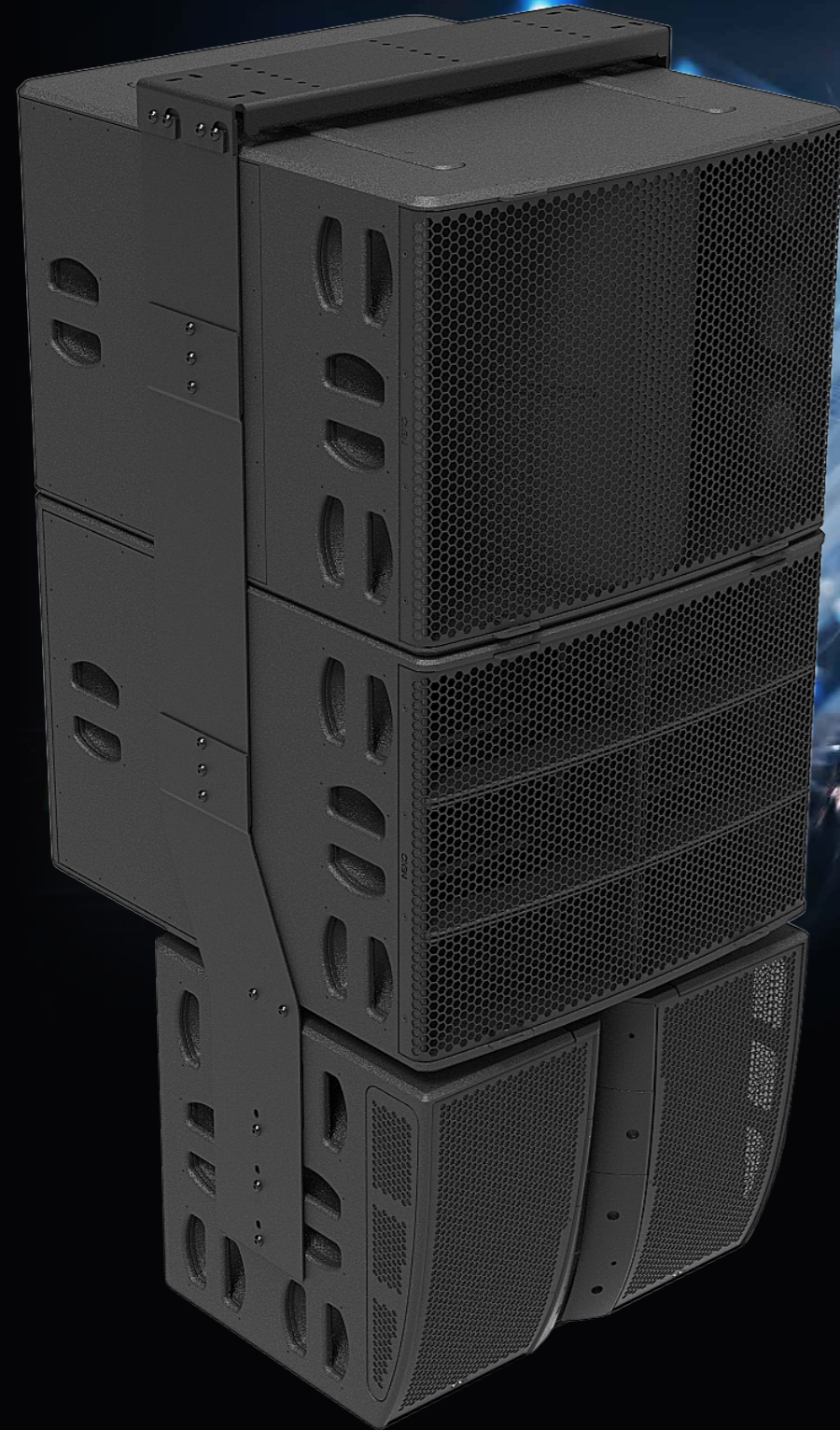

An EDM Powerhouse

The original Alpha system is a legend among club operators who know that the key to filling the dancefloor is dynamic, full range sound with lots of punch and plenty of bass, all delivered at high SPLs and with absolute clarity.

Now Alpha+ builds on that legacy with sophisticated HF dispersion control to ensure that the same, thrilling sound is experienced in every corner of the venue.

A full range of accessories makes it easy to permanently install Alpha+, including brackets for Main, Main + Bass and Main + Bass + Sub configurations.

Goes Where a Line Array Won't

There could be any number of reasons why a line array can't be installed in a particular venue. Theatres are often historic buildings that don't have the rigging points and roof loading to hang a long line array necessary to cover stalls and balconies.

With Alpha+, theatres have a hybrid source solution that's as easy to install as a conventional point source system yet has the coupling and directivity control features of a line array to ensure optimal vertical and horizontal coverage.

And as much as Alpha+ is a relentlessly powerful system, such impact is not achieved at the expense of the clarity and articulation that make NEXO systems such a familiar sight in the world's leading theatres, concert halls and auditoria.



Configure the Perfect System

Stacked or installed, Alpha+ systems are configured from appropriately scaled Main, Bass and Sub-bass modules. Main and Bass modules are used together in a recommended ratio of 1:1.

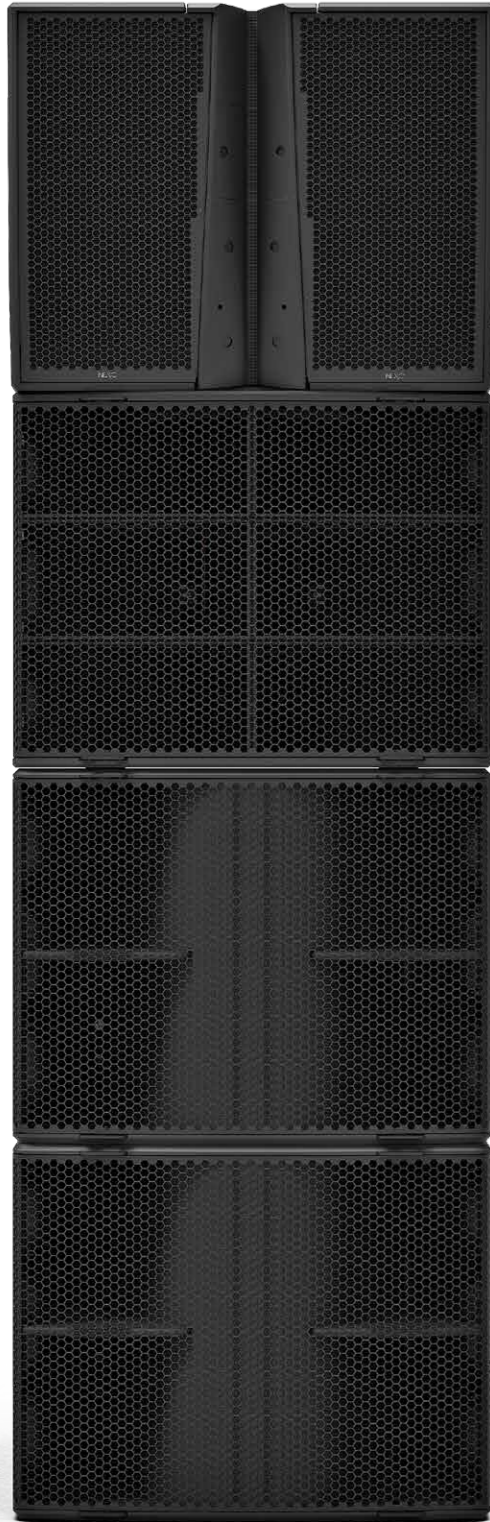

α+ M210

Main Module

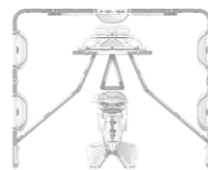

The two-way M210 active Main module uses two lightweight pure MF neodymium 10" drivers horn loaded, and coaxially mounted with four 3" neodymium compression drivers mounted on an innovative articulated waveguide.

Using a custom made 15 mm plywood cabinet of Birch and Poplar with a rounded shape to prevent damage in the corners, the M210 weighs in at 53kg/117lbs and achieves a peak SPL of 148dB. The mid-frequency horn ensures maximum radiating surface and high efficiency.

A unique articulated HF waveguide is used to adjust vertical directivity. Continuously changing horizontal directivity from 120° (bottom) to 60° (top) is tuneable with optional magnetic flanges.



148dB Peak SPL



Horn-loaded 2 x 10" with 4 x 3" HF compression drivers

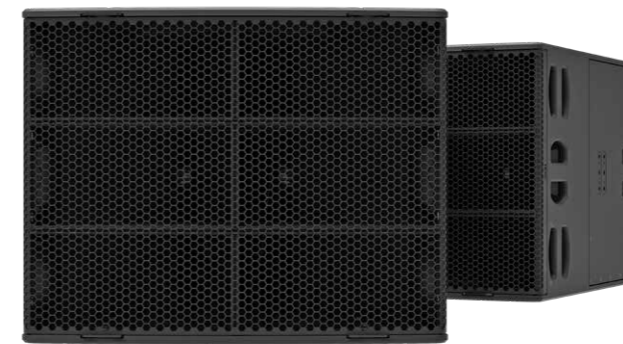

α+ B218

Bass Module

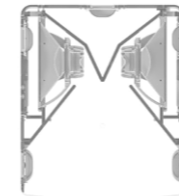

The B218 Bass module uses two high-force 18" drivers coupled in a common cavity loaded with a symmetric bass horn, computer optimised to guarantee ultra-low distortion, even at very high levels.

Using a 15 mm custom made bent plywood shell, with Poplar veneer for the inside layers and Birch for the outside, the B218 weighs in at 77kg/170lbs and achieves a peak SPL of 146dB. The low-frequency horn ensures maximum radiating surface and high efficiency.

Four large comfortable handles on each side plus one at the back of the unit ensure easy manipulation of the B218 in any situation, particularly when used with its dedicated wheel-board and cover.



146dB Peak SPL



Horn-loaded 2 x 18"

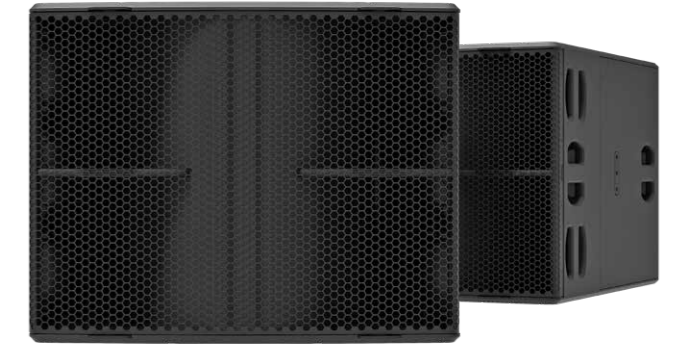

α+ L20

Sub-bass Module

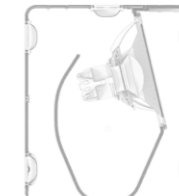

The L20 Sub-bass module uses a single high-excursion 20" driver in a compact, band-pass horn-loaded tuning achieved through two computer optimised shaped ports, ensuring ultra-low distortion even at very high levels.

Built around a 15 mm custom made bent plywood shell using Poplar veneer for the inside layers and Birch of the outside, the L20 weighs in at 59kg/130lbs and achieves a peak SPL of 141dB. The low-frequency horn ensures maximum radiating surface and high efficiency.

Four large comfortable handles on each side ensure easy manipulation of the L20 in any situation, particularly when used with its dedicated wheel-board and cover.



141dB Peak SPL



Band-pass 1 x 20"

Precision Directivity Control

Precision directivity control for the M210 Main module gives Alpha+ many of the benefits of line array coupling, along with the convenience and easy deployment typical of point source systems.

Horizontal Directivity

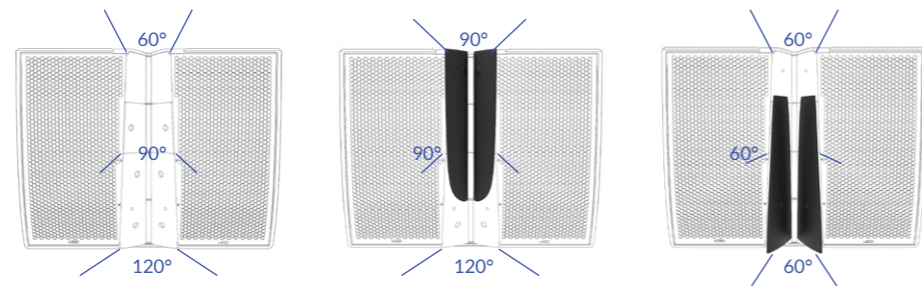

The continuously varying horizontal directivity from 60° at the top of the M210 Main module to 120° at the bottom can be modified to 90°/120° or 60°/60° using magnetic flanges (See Accessories page 20).

Vertical Directivity

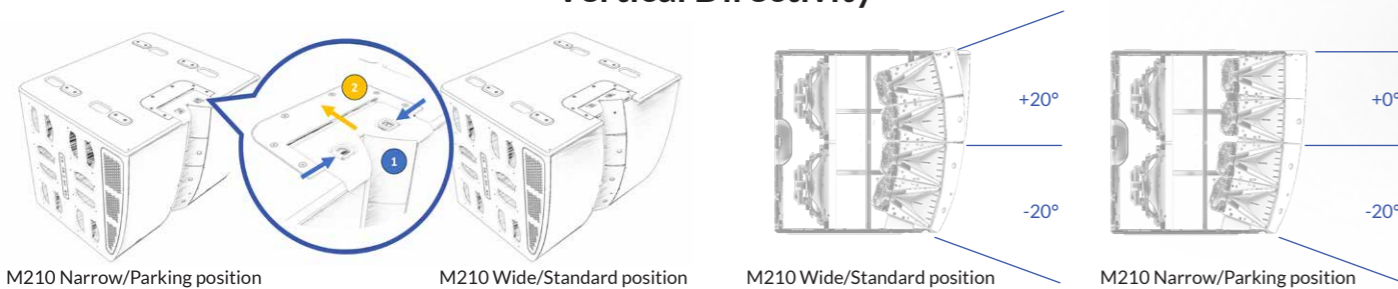

The waveguide block can be 'unlocked' and its articulation changed from Narrow vertical coverage (-20°/+0°) to Wide/Standard (-20°/+20°).



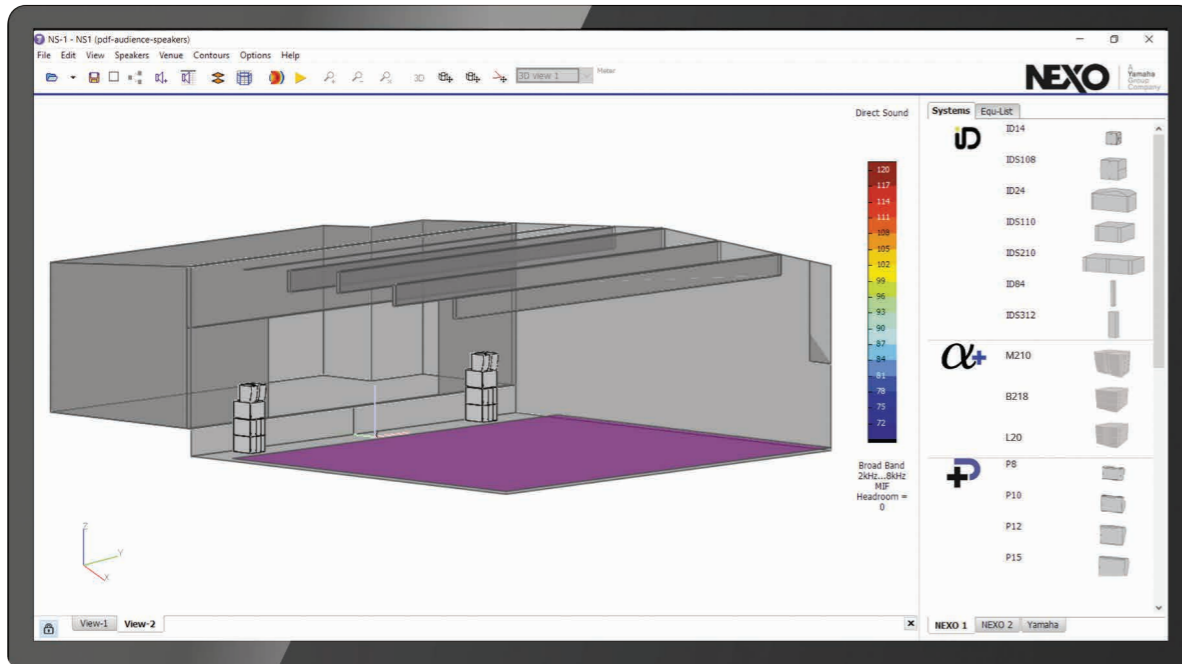

NS-1 System Configuration Software

Design the optimum system and predict its performance

NS-1 System Configuration Software helps system designers and installers to configure any line source or point source from NEXO's catalogue, thanks to intuitive yet powerful tools applied to their own geometry. NS-1 not only assists in achieving the best SPL coverage, but also certifies that mechanical constraints are satisfied. And NS-1 enables users to create and present robust sound design proposals, including the speaker list, and also gain and delay to apply in the amplification and control chain.

Of course, NS-1 includes Alpha+ modules, but one of the great advantages of the system is its ease of deployment. In many applications, it's simply a case of showing up, stacking up and switching on.



NXAMP4X4MK2 Powered TD Controller

The perfect amplification and processing partner for Alpha+

Delivering 4 X 4500 Watts from just 3U of rack space, the NEXO NXAMP4X4Mk2 Powered TD Controller is the perfect compact, light-weight amplification and processing solution for Alpha+. A single amplifier can power a single stack of Alpha+, with 2 channels for the active M210 Main module, 1 channel for the B218 Bass module and 1 channel for a pair of L20 Subs.

Combining advanced signal processing and 32-bit/96KHz converters with four state-of-the-art Class D amplifiers, NXAMP4X4Mk2 exhibits formidable power, precision control and a highly articulate and musical sonic signature.

Alpha+ modules have been developed to match precisely the output power of the NXAMP4X4Mk2 and take advantage of new processing algorithms.

Horizontal coverage of the M210 has been optimised with FIR filters by adapting the phase between MF and HF on a wider frequency range than the traditional unique crossover frequency point.

Advanced Dynamic Processing optimises the match between maximum excursion with the NXAMP4X4Mk2 output voltage capacity, resulting in a highly dynamic sound while preventing triggering of the thermal limit of the driver.

And particular care has been taken also to adjust the group delay of the Alpha+ system ensuring a tight sound over the whole spectrum while keeping the ease of use of interoperability with other NEXO products.



Typical Systems

FOH system for a smaller event or side fill on a large stage

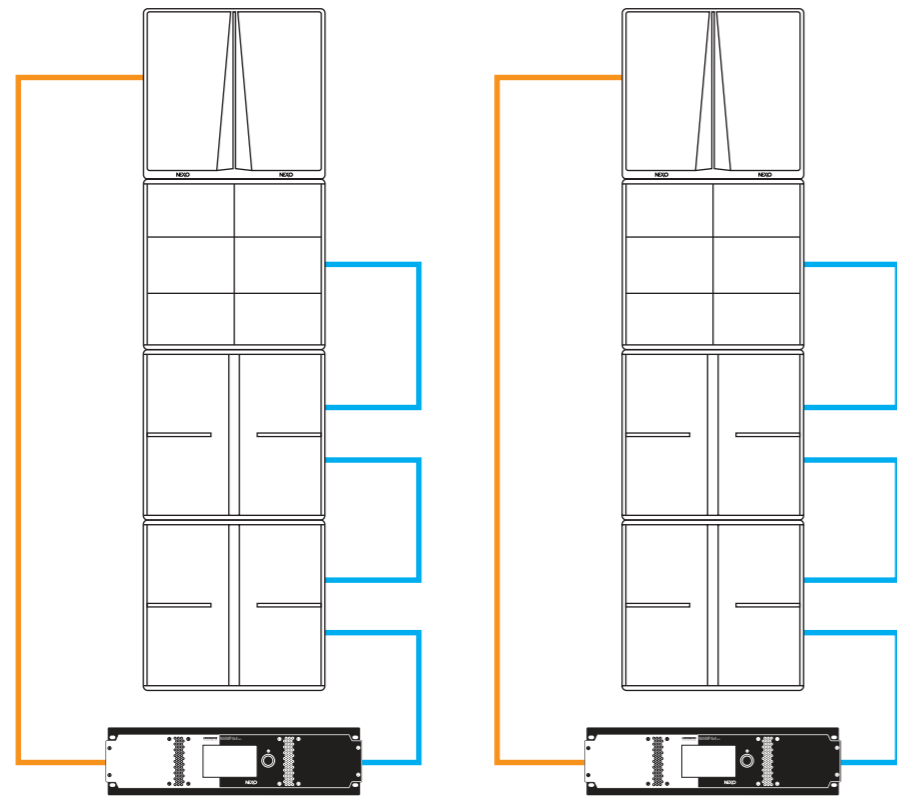

1 x M210 + 1 x B218 + 2 x L20 per side powered by 1 x NXAMP4X4MK2 per side

FOH system for mid-size outdoor event

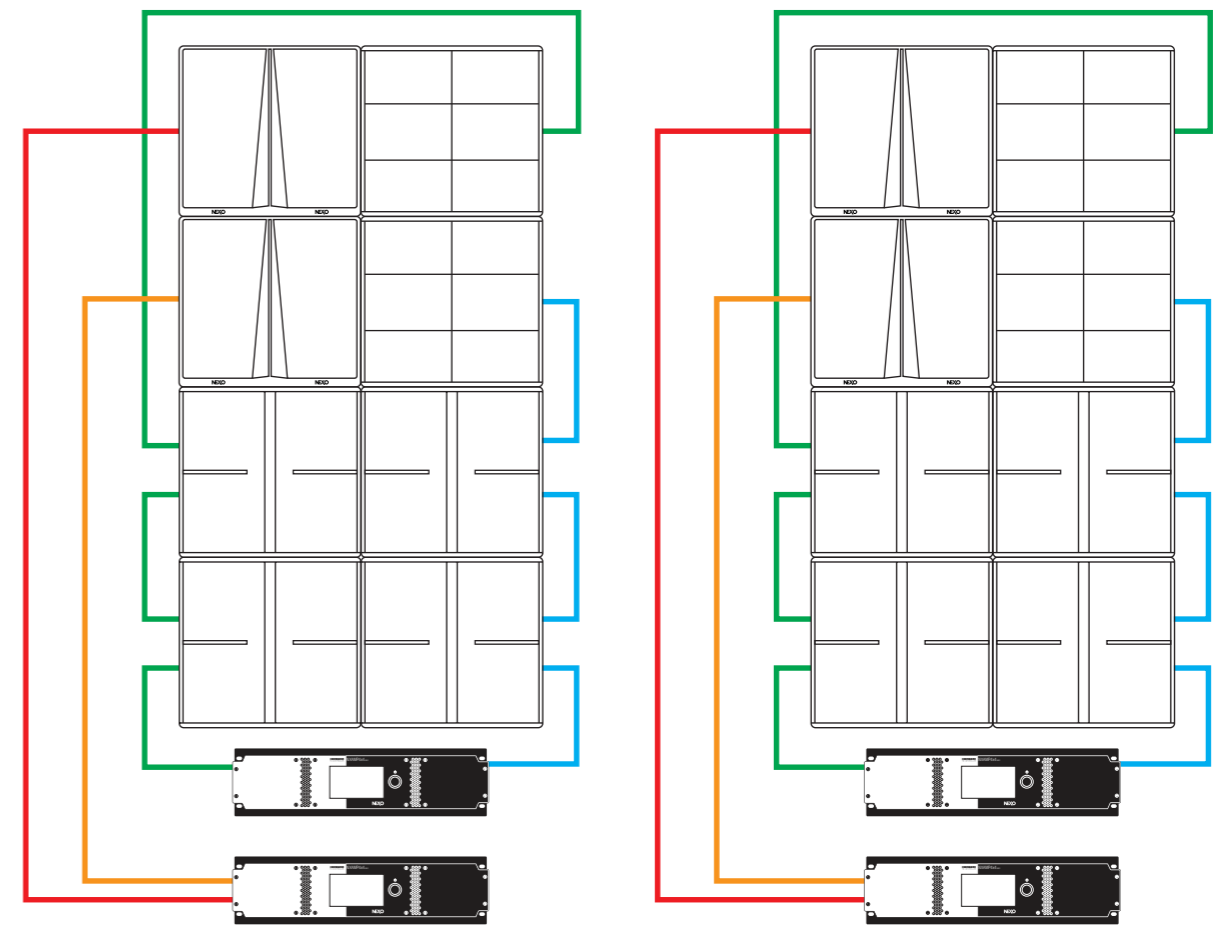

2 x M210 + 2 x B218 + 4 x L20 powered by 2 x NXAMP4X4MK2 per side

Typical Systems

Theatre system

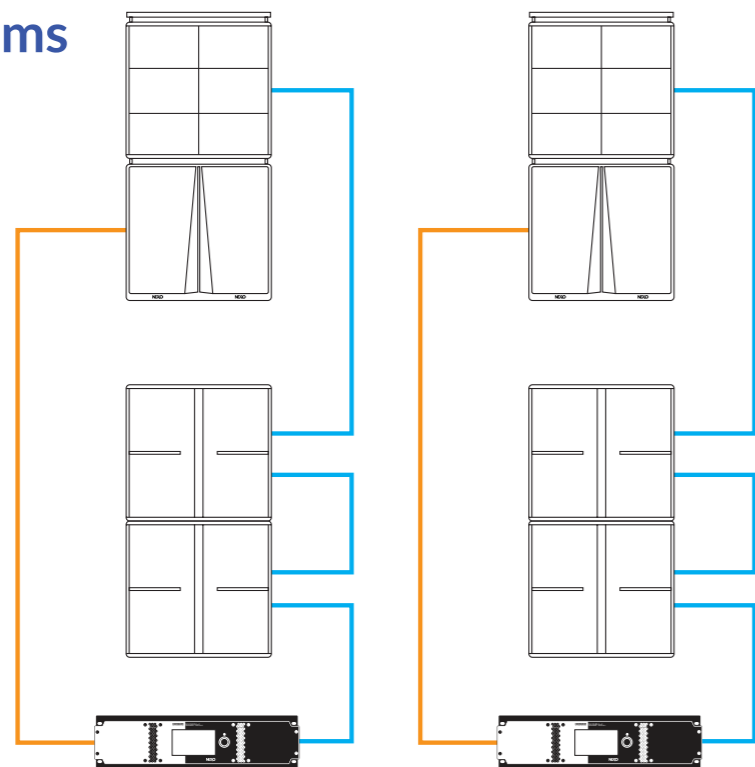

1 x B218 + 1 x M210 + 2 x L20 powered by 1 x NXAMP4X4MK2 per side

Distributed Club system

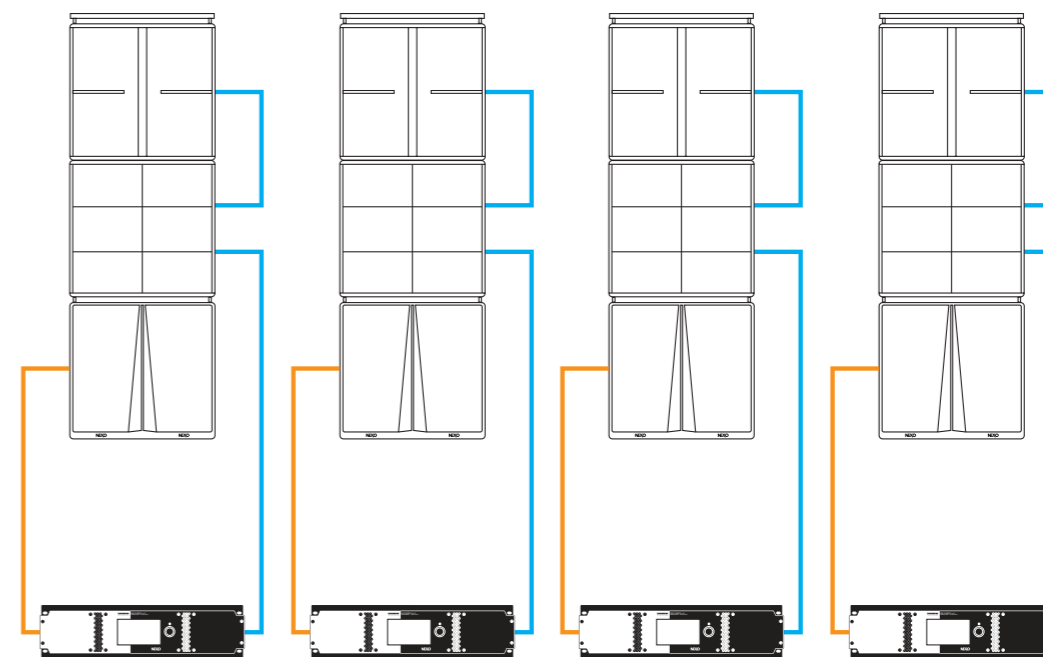

1 x L20 + 1 x B218 + 1 x M210 powered by 1 x NXAMP4X4MK2 per cluster

Immersive FOH system

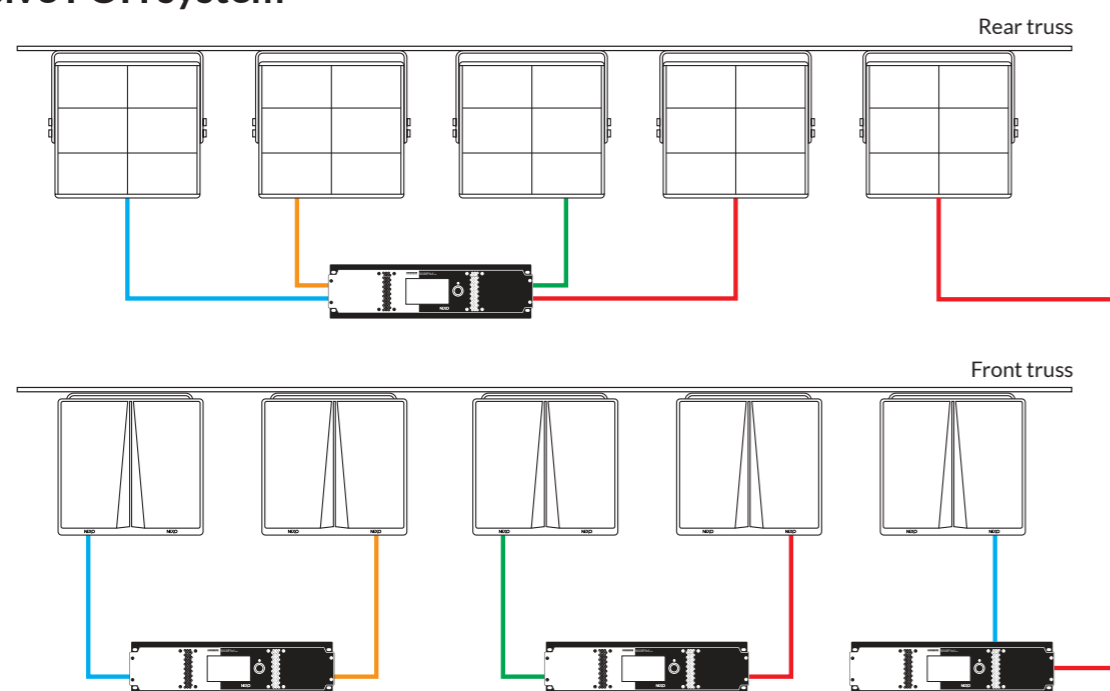

5 x B218 and 5 x M210 powered by 4 x NXAMP4X4MK2 on two separate trusses

Directivity Flanges

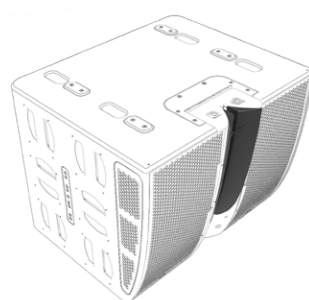

ANT-FLG90
90° Directivity Flanges for M210

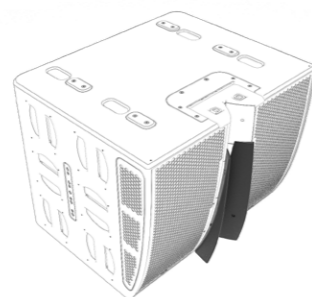

ANT-FLG60
60° Directivity Flanges for M210

Fixed Installation Accessories

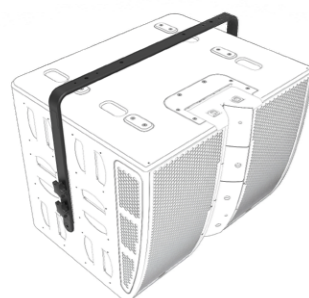

VNU-HBRK01
U bracket for L20 / B218 / M210

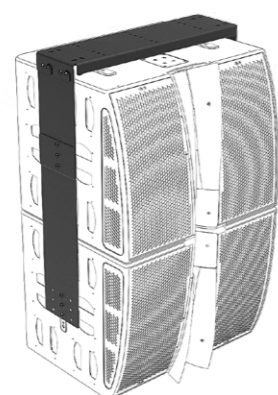

ANI-LK01
M210 under M210

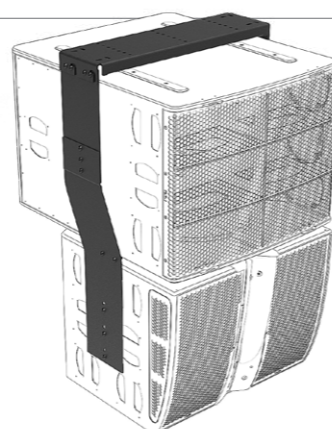

ANI-LK02
M210 under B218

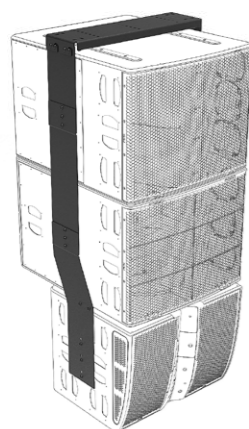

ANI-LK03
M210 under B218 and L20

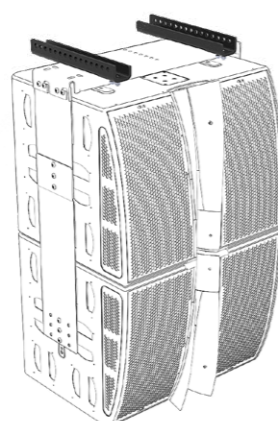

ANI-EXB01
Extension bar for ANI-LK01

Touring Accessories

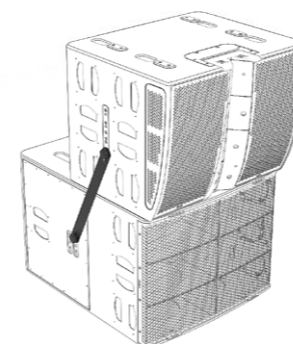

VNT-CPL04
Link L20 / B218 / M210

Covers and Wheelboards

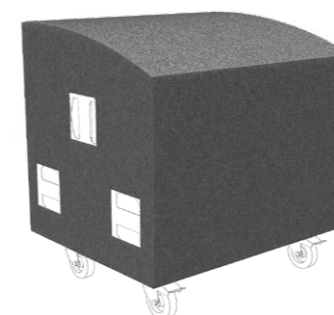

ANT-COVM210
Cover for M210 with casters

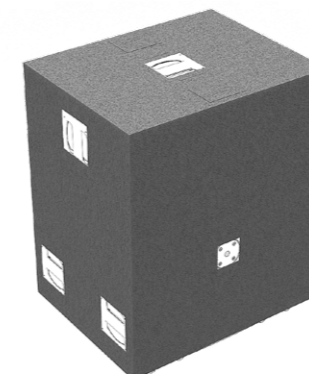

ANT-COVB218
Cover for B218 on wheelboard

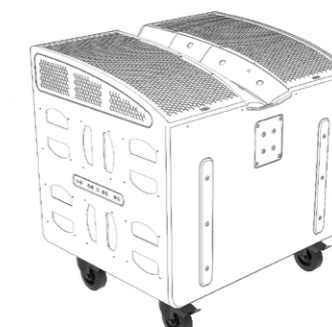

VNT-CAS01
Casters for M210

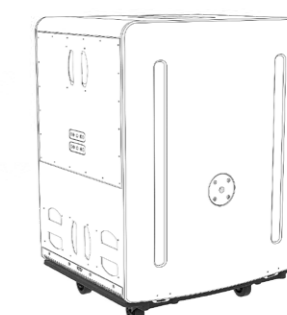

VNT-WB01
Wheelboard for L20 / B218

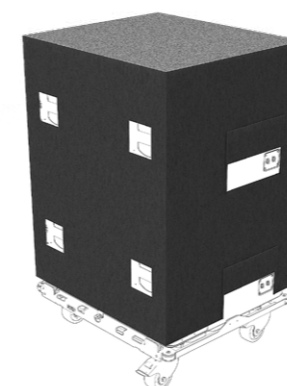

VNT-COV02
Cover 2xB218 or L20 on
VNT-DOLLY01

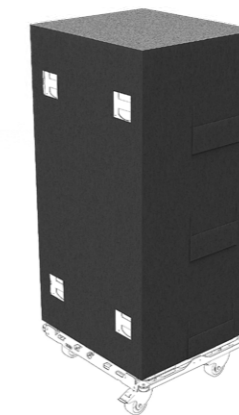

VNT-COV03
Cover 3xB218 or L20 on
VNT-DOLLY01

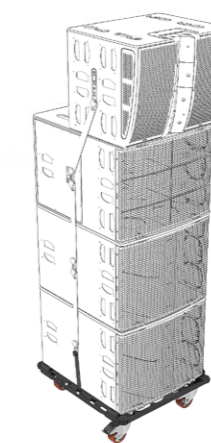

VNT-DOLLY01
Dolly for L20 / B218 / M210

Specifications

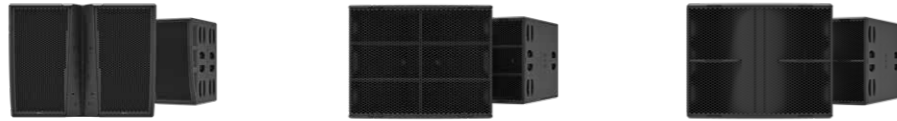

	M210 Main module	B218 Bass module	L20 Sub-bass module
Frequency Response @-6 dB	160 Hz to 20 kHz	75 Hz to 160 Hz	28 Hz - 120 Hz
Peak SPL@1m	148 dB Peak	146 dB Peak	141 dB Peak
Operating Voltage	45 Vrms (150 Vpeak)	65 Vrms (180 Vpeak)	80 Vrms (180 Vpeak)
Crossover Frequency	500 Hz to 1500 Hz overlap, optimized with proprietary software NEXO Polar Combiner	75 Hz	60 Hz, 85 Hz, 120 Hz
Vertical Dispersion	Adjustable (-20°/+20° Default mode) or (-20°/+0° Low Throw mode)		
Horizontal Dispersion	120° (bottom) to 60° (top) continuously		
Nominal Impedance	4 Ω + 4 Ω	4 Ω	4 Ω
Product Features			
Components		2 x Neodymium 18" 8 Ohms	1 x Neodymium 20" 4 Ohms long excursion
LF Components	2 x Neodymium 10" 8 Ohms		
HF Components	4 x Neodymium 3" voice coil 1.4" throat driver on a BEA/FEA optimized Wavesource		
Connectors	2 x NL4, 4 poles connectors.		
Rigging points	1 x universal accessory fit on each side + 1 x M20 thread for Pole Stand on top	2 x universal accessory fit on each side + 1 x M20 thread for Pole Stand on top	1 x universal accessory fit on each side + 1 x M20 thread for Pole Stand on top
Material	Custom made bent plywood of baltic birch and poplar		
Finish	Black or White structural paint		
Front Finish	Magnelis® steel front grille		
Height x Width x Depth	598mm x 755mm x 632 mm (23.5" x 29.7" x 24.9")	594mm x 755mm x 905 mm (23.4" x 29.7" x 35.6")	
Weight: Net	53 kg (117 lbs)	77 kg (170 lbs)	59 kg (130 lbs)
Operating temperature range	0°C - 40 °C (32° F - 104° F)		
Storage temperature range	-20 °C - 60 °C (-4 °F - 140° F)		
System Operation			
Recommended powering solution	NXAMP4x4mk2 Powered TDcontroller: Up to 2 x M210 on 2 x channels (MF/HF)	NXAMP4x4mk2 Powered TDcontroller: Up to 2 x B218 per channel	NXAMP4x4mk2 Powered TDcontroller: Up to 2 x L20 per channel
Optional powering solution	NXAMP4x1mk2 Powered TDcontroller (Bridged): Up to 2 x M210 per amplifier (MF/HF) NXAMP4x2mk2 Powered TDcontroller: 1 x M210 on 2 x channels (MF/HF)	NXAMP4x1mk2 Powered TDcontroller (Bridged): Up to 1 x B218 per channel NXAMP4x2mk2 Powered TDcontroller (Bridged): 1 x B218 per channel	NXAMP4x1mk2 Powered TDcontroller (Bridged): 1 x L20 per channel NXAMP4x2mk2 Powered TDcontroller (Bridged): 1 x L20 per channel

Deployment of NEXO systems should always comply with current control of noise, hearing protection and manual handling legislation, and NEXO products should always be operated in accordance with their accompanying Operating Instructions.

NEXO NS-1 System Configuration software can be used to predict sound pressure levels and coverage of NEXO systems in a specified venue or setting, also certifying that mechanical constraints are satisfied.

NEXO is a founding member of the HELA initiative (Healthy Ears, Limited Annoyance) that aims to transform the live music and events industry by advancing safe, healthy, and sustainable sound practices through education, research, and collaboration.



Scan for more information

α + series

NEXO
Parc d'Activité
du Pré de la Dame Jeanne
B.P.5
60128 Plailly
FRANCE
Tel: +33 (0)3 44 99 00 70
Fax: +33 (0)3 44 99 00 30
E-mail: info@nexo.fr



©2025 NEXO S.A. All Rights Reserved.
All NEXO trademarks and service marks are the property of NEXO S.A., its subsidiaries and affiliated companies

nexo-sa.com

Thinking. Inside the box.

NEXO | A
Yamaha
Group
Company