

Bumper for GEOM10

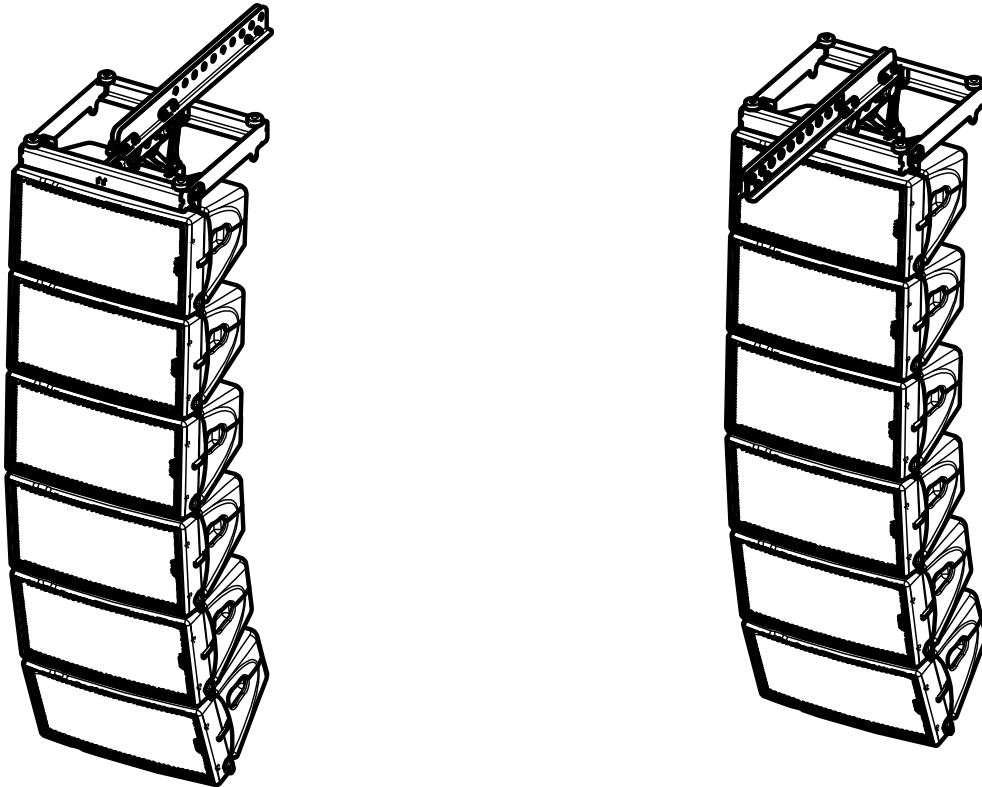

Contents:

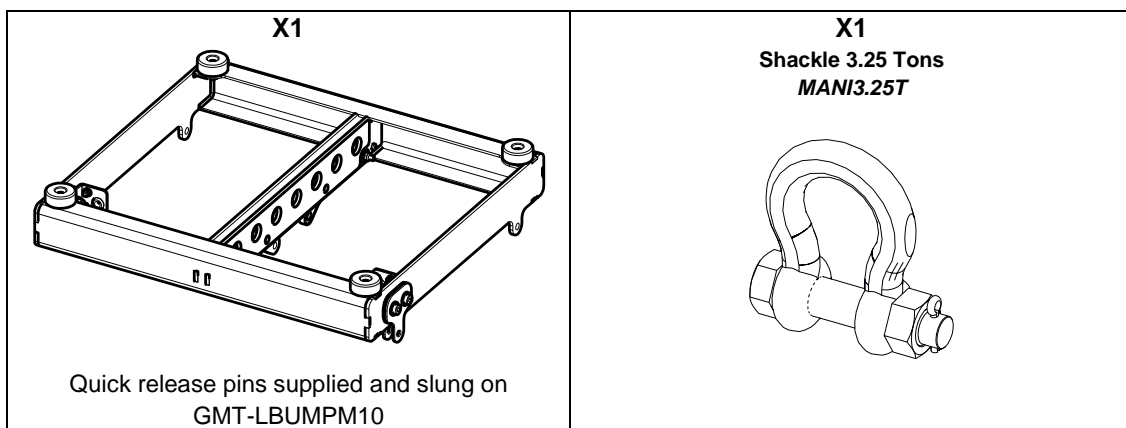

Weight: 8 kg / 18 lb (without shackle)

Dimensions:

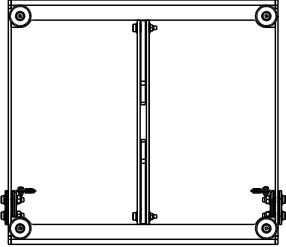
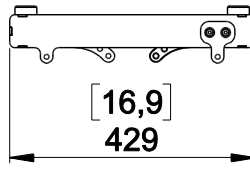
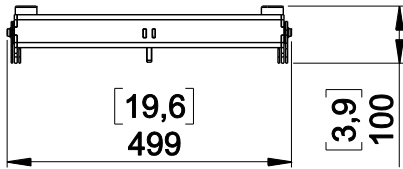

Use: Max 12x GEOM10 flown or 3x GEOM10 stack

HF on the right (stack)

<p>Remove the two quick release pins <i>BL0820AR</i>, and the quick release pin of <i>LBUMPM10</i> link bar <i>BL0825AU</i>.</p>	<p>Take out <i>GEOM10</i> link bar. Place <i>GEOM10</i> and lock with the 2 quick release pin <i>BL0820AV</i>.</p>	<p>Adjust the angle with the <i>LBUMPM10</i> link bar. Lock with the quick release pin <i>BL0825AU</i>.</p>

HF on the left (stack)

<p>Remove the quick release pin of <i>LBUMPM10</i> link bar <i>BL0825AU</i> to unlock it.</p>	<p>Take out <i>GEOM10</i> link bar. Pull the 2 <i>AutoRig</i> in automatic lock position and place <i>GEOM10</i>. Check that it is properly engaged.</p>	<p>Adjust the angle with the <i>LBUMPM10</i> link bar. Lock with the quick release pin <i>BL0825AU</i>.</p>

WARNING: Use shackle model: Alloy Bolt Type Shackles 3.25 Tons

Use NEXO Simulation Software for mechanical prediction

- NEXO cannot accept responsibility for accidents caused by any factor other than defects in this product itself.
- Please check the web site nexo-sa.com for the latest update.



www.nexo-sa.com
 ZA du pre de la Dame Jeanne
 60128 PLAILLY-France

- Read this document before using.
- Keep this document.
- Observe all warnings and cautions.

