

Extension Bar for GEOM6

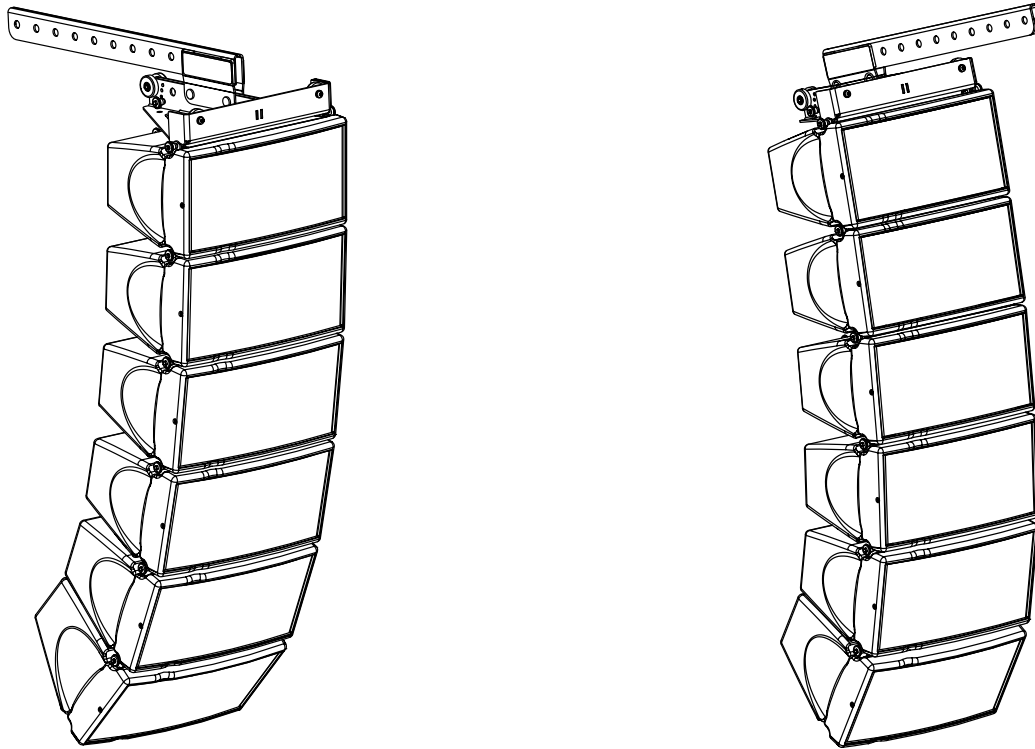
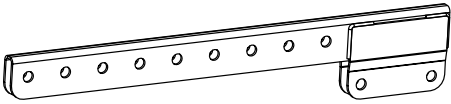
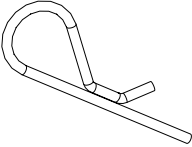
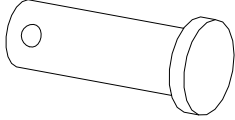

Contents:

<p style="text-align: center;">X1</p> 	<p style="text-align: center;">X2</p> 	<p style="text-align: center;">X2</p> 
--	--	--

Weight: 1.9 kg / 4.2 lb



nexo-sa.com
ZA du Pre de la Dame Jeanne
60128 PLAILLY - France

- Read this document before using.
- Keep this document.
- Observe all warnings and cautions.



Dimensions:

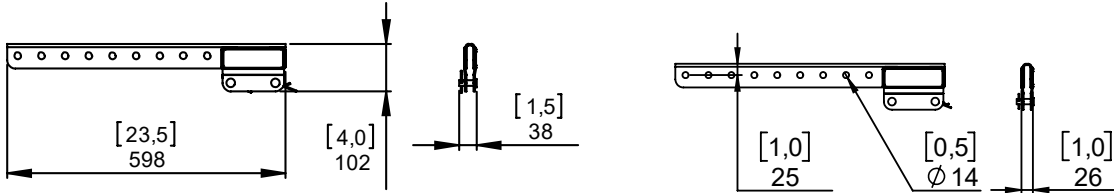

!! Rated for a maximum of 12x GEOM6

Assembly:

Connect GMT-EXBAR to GMT-BUMPER by inserting EXBAR clevis pins into GMT-BUMPER “B” and “D” holes.

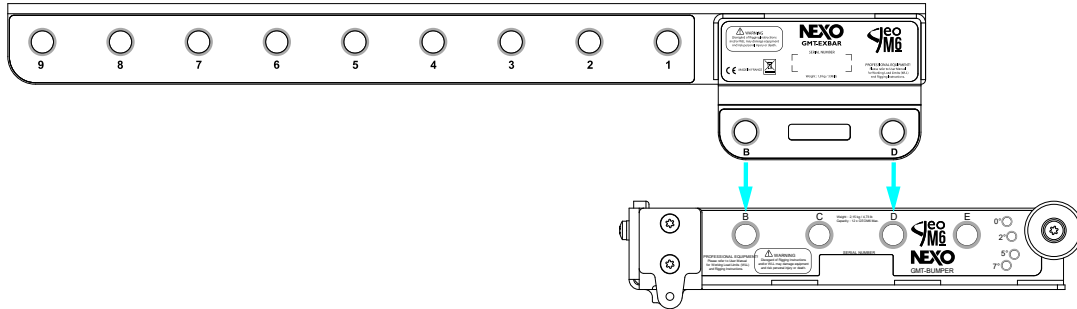

Use:

Negative Tilt

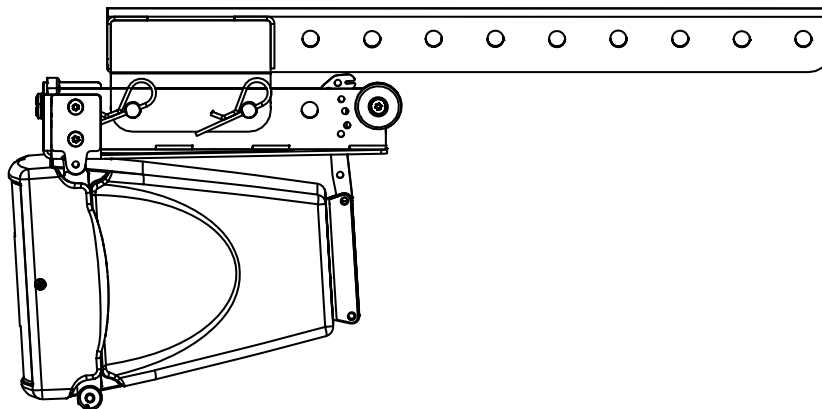

Positive Tilt

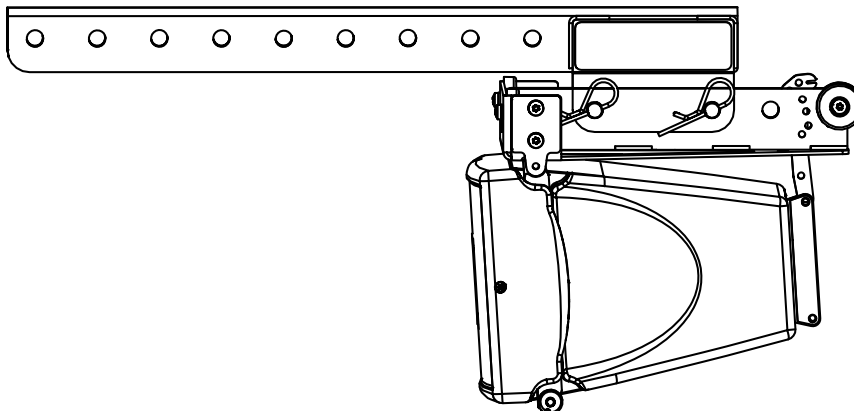

IMPORTANT

Ensure all pins are properly locked
Check NS-1 for mechanical Safety Working Load

- NEXO cannot accept responsibility for accidents caused by any factor other than defects in this product itself.
- Please check the web site nexo-sa.com for the latest update.



nexo-sa.com
ZA du Pre de la Dame Jeanne
60128 PLAILLY - France

- Read this document before using.
- Keep this document.
- Observe all warnings and cautions.

